

# Installation instructions for

## COONAWARRA PICNIC SETTING

**CAUTION:** This Setting is Approx 230kg. Do not attempt to assemble this product by yourself. Manual handling is required.

Flat pack on arrival

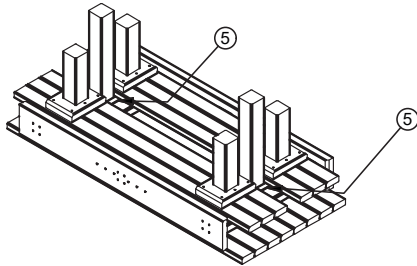

**STEP 1:** Place seat tops either side of table. Place base plates onto seat top legs. Lightly tap leg into recess with hammer. Screw into place using (Item 4) 14gx100 screws.

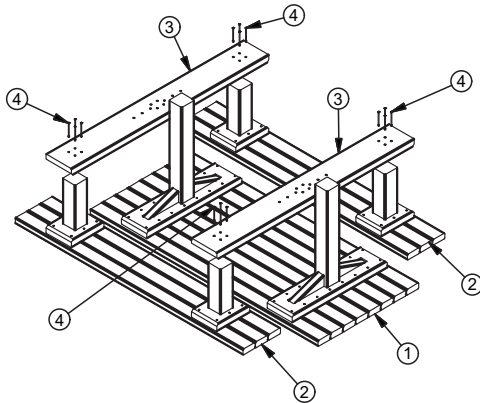

**STEP 2:** With assistance lift assembled seating onto table top legs. Lightly tap legs into recess with hammer. Screw into place using (Item 4) 14gx100 screws.

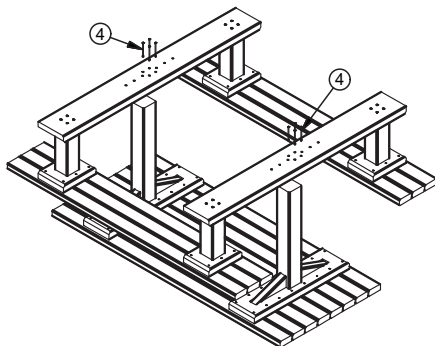

©Integrated Recycling P/L 2017

Parts List - Per Sleeve		
1	Table Top	1
2	Base Plate	2
3	Seat Top	2
4	14Gx100 Bugel Batten Screw	24
5	90x40 (for Transport Only)	2

### TOOLS REQUIRED:

- Hammer
- 5mm Allen Key

**STEP 3:** Once assembly is finished, with assistance turn over length ways. This will limit stress put onto seat legs when turning over.

