

# Installation instructions for

TASMAN 1800 SEAT

Flat pack on arrival

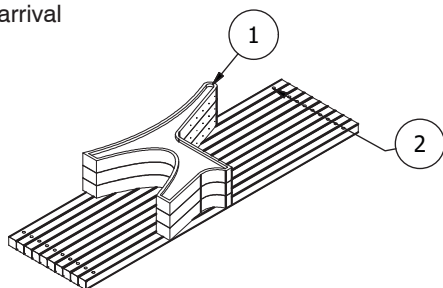

**STEP 1:** Place Legs (1) apart on ground. Screw bugle batten screws (3) through 50x50 profile (2) until the point shows through other side. Align with pre drilled holes in leg. Tighten screw down being carefull not to over tighten.

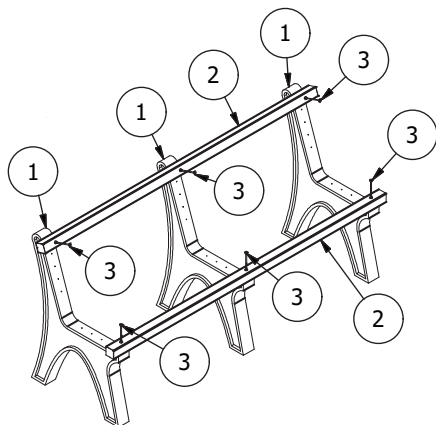

**STEP 2:** Repeat previous step with remaining 50x50 profiles (2)

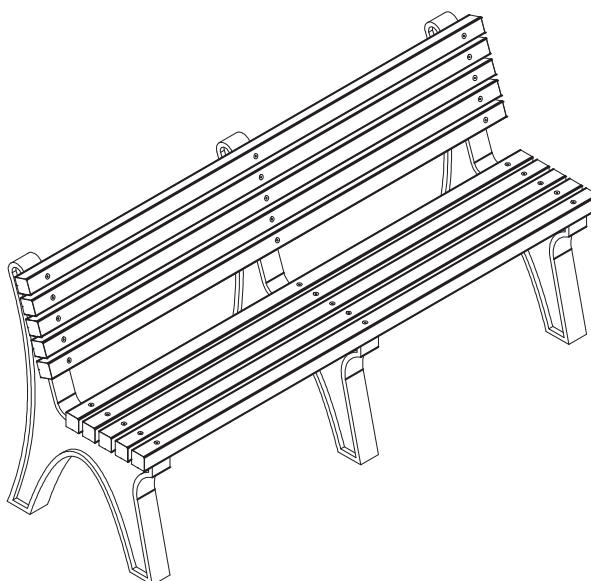
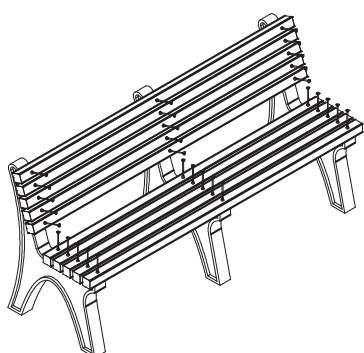

## Parts List - Per Sleeve

1	Tasman Extruded Leg	3
2	50X50@1800 Envire	10
3	14Gx100 Bugle Batten Screw	30

## TOOLS REQUIRED:

- 1x Allen key driver (Supplied 1 per order)
- Drill or impact driver

